

This manual is for reference and historical purposes, all rights reserved.

This page is copyright© by M. Butkus, NJ.

This page may not be sold or distributed without the expressed permission of the producer

I have no connection with any camera company

On-line camera manual library

This is the full text and images from the manual. This may take 3 full minutes for the PDF file to download.

If you find this manual useful, how about a donation of \$3 to: M. Butkus, 29 Lake Ave., High Bridge, NJ 08829-1701 and send your e-mail address so I can thank you. Most other places would charge you \$7.50 for a electronic copy or \$18.00 for a hard to read Xerox copy.

This will allow me to continue to buy new manuals and pay their shipping costs.

It'll make you feel better, won't it?

**If you use Pay Pal or wish to use your credit card,
click on the secure site on my main page.**

INSTRUCTIONS



LEICA R 4



321.111-117

Engl.

Perfect pictures without technical problems – the outstanding feature of the LEICA® R 4.

Its optimum adaptation to the task in hand and to the photographic situation is based on its 5 programs, which are combined with the well-tried alternative methods of LEITZ largefield integrating and LEITZ selective exposure measurement.

With interchangeable lenses from 15 to 800mm focal length and a comprehensive range of accessories the LEICA R 4 offers a universal system which leaves nothing to be desired.

These instructions are not designed to prevent you from taking photographs, but to tell you in a few words how simple it is to handle the LEICA R 4.

We hope that photography with your new LEICA R 4 will give you much pleasure and success.

ERNST LEITZ WETZLAR GMBH

Brief instructions for perfect pictures without technical problems with the automatic programs.

Before taking photographs: Details on page

- | | |
|--|----|
| 1) Attach the carrying strap | 6 |
| 2) Insert and test batteries – test button (13), LED (12) | 7 |
| 3) Insert the lens | 9 |
| 4) Set film speed – locking button (13), knurled ring (15) | 10 |
| 5) Insert film | 11 |
| 6) Wind the shutter | 10 |
| 7) Select automatic program  – program selector (6) | 30 |
| 8) Stop the lens down til minimum aperture – aperture preselection ring (21) | 30 |
| 9) Focus – distance setting ring (23) | 36 |
| 10) Press the release button | |

To enable you to utilize the universal possibilities of the LEICA R 4 to the full, please read the detailed instructions.

Contents

Brief instructions	2	Uniform groundglass screen with grid division	37
Brief description	4	Clear glass plate with crosslines	37
Attaching the carrying strap	6	Correction lenses	38
Inserting and testing the batteries	7	Eyepiece blanking	39
Inserting the lens	9	Multiple exposures	40
Removing the lens	9	Self-timer	40
Rapid transport lever	10	Depth-of-field lever	41
Setting the film speed	10	Depth-of-field scale	41
Inserting the film	11	Holding the camera correctly	42
Removing the film	14	Flash synchronisation	43
Switching on the exposure system	14	Automatic switch-over to "X"	44
The alternative exposure measuring methods	15	Interchangeable lenses	45
LEITZ largefield integrating measurement	16	Design of the LEICA R lenses	46
LEITZ selective measurement	16	Automatic spring-back diaphragm	46
Exposure corrections	17	Lens hoods	47
Measuring with working aperture	18	Filters	48
Insufficient light for measurement	18	The use of filters	49
Long-time range	19	The use of existing LEICA R lenses and accessories	50
Working diagram of the exposure meter	20	LEICA M lenses on the LEICA R 4	51
Selecting the programs	22	Care of the LEICA R 4	51
Shutter speed ring	23	MOTOR-WINDER R 4, MOTOR-DRIVE R 4	52
Automatic shutter speed control with LEITZ LEITZ largefield integrating measurement	24	Remote-control LEICA R electronic control unit	54
Automatic shutter speed control with LEITZ selective measurement	26	DB LEICA R 4 Databack	54
Automatic aperture control with LEITZ largefield integrating measurement	28	Cases	55
Automatic program with LEITZ largefield integrating measurement	30	Suitability for use in the tropics	55
Manual setting with LEITZ selective measurement	32	Camera spare parts	56
The viewfinder as a composition and control centre	34	Focusing screens	56
Focusing with the universal focusing screen	36	After Sales Service	56
Interchangeable focusing screens	37	Enlargers	57
Uniform groundglass screen, micro-prism screen	37	Projectors	57
		LEICA Information Service	58
		LEICA School	58
		"LEICA Fotografie" magazine	59
		In these instructions the camera is called the LEICA R 4.	



Ret.-Nr. 24 623-111

Brief description

- | | | | |
|---|---|----|---|
| 1 | Automatic frame counter | 10 | LED for self-timer |
| 2 | Control window for film transport | 11 | Locking button for exposure correction |
| 3 | Lever for rapid shutter wind and film transport | 12 | LED for battery test |
| 4 | Release button with thread for cable release | 13 | Locking button for ISO (ASA/DIN) setting of the exposure meter, battery test knob (C) |
| 5 | Shutter speed ring | 14 | Folding rewind crank |
| 6 | Program selector | 15 | Film-speed setting ring |
| 7 | Viewing window for the set program | | |
| 8 | Accessory shoe with centre and control contact | | |
| 9 | Illuminating window for shutter-speed display | | |



Ret.-Nr. 24 624-111

- 16 Scale for exposure correction
- 17 Electronic self-timer
- 18 Bayonet lock
- 19 Depth-of-field lever
- 20 Red dot marking for lens change
- 21 Aperture preselection ring
- 22 Depth-of-field scale
- 23 Distance setting ring

- 24 Flash contact
- 25 Eyelet for carrying strap
- 26 Viewing window for inserted film
- 27 Eyepiece blank
- 28 Viewfinder eyepiece, correction lenses can be inserted
- 29 Cap for battery compartment
- 30 A 1/4 tripod thread
- 31 Rewind release and double-exposure button

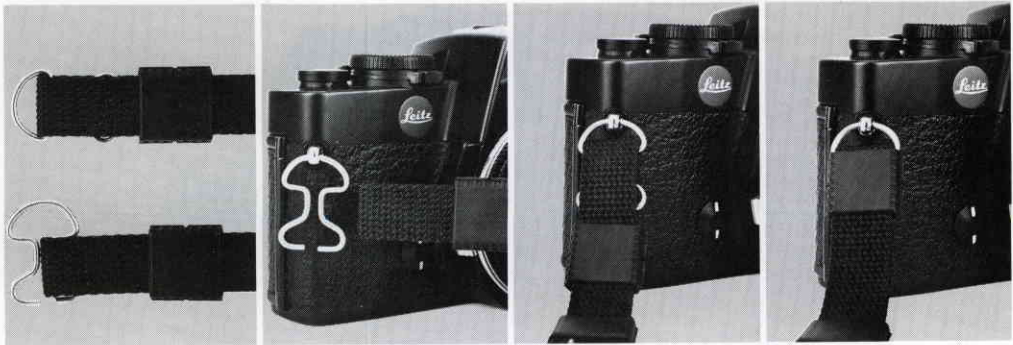

Attaching the carrying strap

Attach the carrying strap to the eyelets (25).

Remove the metal hooks from the carrying strap and hook them into the eyelets on the camera. Replace the carrying strap and push the securing loops over the metal hooks.

A small pocket for 2 spare batteries is fixed to the carrying strap.

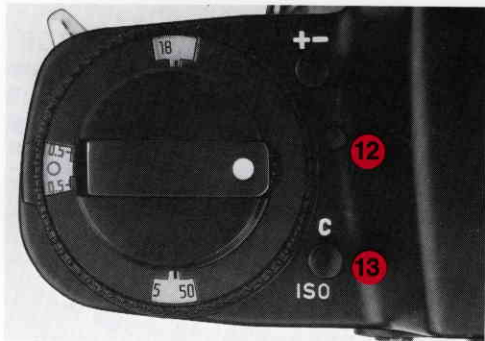

Ret.-Nr 24 564-111

Inserting and testing the batteries

The LEICAR 4 requires electrical power for exposure measurement shutter/aperture control. This is supplied by 2 1.55v silver oxide button cells.

To insert the batteries unscrew with a coin and remove the cap (29) on the underside of the camera body. Remove films of oxide from the batteries with a clean cloth and insert the batteries in the cap according to the insertion symbols. Screw the cap and batteries into the baseplate of the camera.

Check the state of the batteries before you start taking photographs, especially when

you have not used the camera for a prolonged period. Press the battery testing button (13), marked "C" on top left of the camera. The LED (12) fitted in front of the battery test button lights up in red when the batteries are in working order. The battery test knob should remain pressed for about 5 seconds. A noticeable reduction in the light intensity of the LED during indicates the imminent exhaustion of the batteries, which should be replaced.

Important

When the MOTOR-WINDER R 4 or MOTOR-DRIVE R 4 is attached, the batteries are tested when the exposure system is simultaneously switched on, for instance by means of pressing the locking button on the program selector (see "Switching on the exposure system", page 14).

Designation and main uses:

Manufacturer	Photographic Deaf aids		Watches
Manufacturer	Photographic Deaf aids equipment		
EVERREADY	-	S76E	-
MALLORY	MS76H	MS76H	10L14
MAXEL	SR44F	-	
NATIONAL	G13	G13	
RAY-O-VAC	RS76G	RS76G	
UCAR	EPX76	S76E	No. 357
VARTA	V76PX	V76HS	No. 541

Tips for battery care and use:

Store batteries in a cool and dry place.
Do not use new and used batteries together.

The batteries cannot be recharged.
Do not throw used batteries into the fire.



Ref.-Nr. 24 632-111

Inserting the lens

Grip the lens by the fixed ring (22). Make the red dot (20) on the lens mount face the bayonet lock (18) on the camera body. Insert the lens in this position. After a slight clockwise turn the lens clicks into position.



Ref.-Nr. 24 631-111

Removing the lens

Independently of the distance and aperture setting the LEICA R lenses are exchanged as follows:
Grip the lens by the fixed ring (22). Depress the bayonet lock (18) on the camera. Turn the lens anticlockwise and remove it. Change lenses in the shadow of your body.



Ref.-Nr. 24 655-111

Rapid transport lever

The rapid transport lever (3) transports the film, winds the shutter, and operates the film counter (1).

When the lever is turned out (standby position) the thumb can be moved behind it and thereby securely support the camera.

When the MOTOR-WINDER R 4 or MOTOR-DRIVE R 4 is attached, consult instructions for the MOTOR-WINDER or MOTOR-DRIVE respectively.

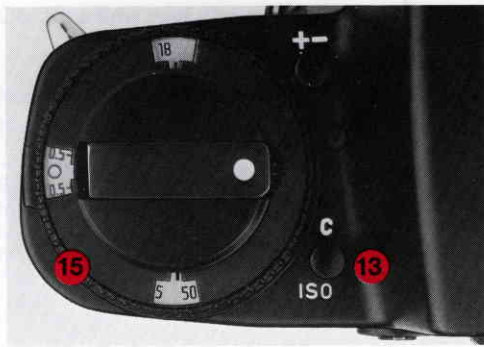

Ref.-Nr. 24 564-111

Setting the film speed

To set the exposure meter for the speed of the film in the camera press the locking button (13) and at the same time rotate the setting ring (15) until the desired film speed is displayed in the viewing windows (DIN at the front, ASA at the rear).

The adjustment range extends from ISO 12/12° (ASA 12/12 DIN) to ISO 3200/36° (ASA 3200/36 DIN). ISO is the international scale unit for film speed.

Inserting the film

Pull up the rewind crank (14) to open the camera back*. After some spring force has been overcome the camera back opens automatically. The film counter returns to "S" (start).

Wind the shutter with the rapid transport lever and release it.

* = The operation is identical with the Databack DB LEICA R 4 attached.



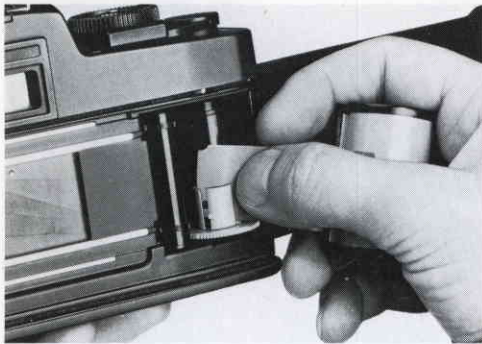

Pick up the film cartridge as illustrated above. The emulsion side points to the viewer. Push the end of the film obliquely from above into one of the slots of the take-up spool. Ensure that the end of the film is fully gripped by at least one lug and protrudes under the next lug.

Fully pull up the rewind crank and insert the film cartridge in the empty film cartridge chamber. New push in the rewind crank. The edge of the film must be parallel to the film guide and the sprockets of the transport drum must engage in the perforation holes of the film when the rapid transport lever is operated.

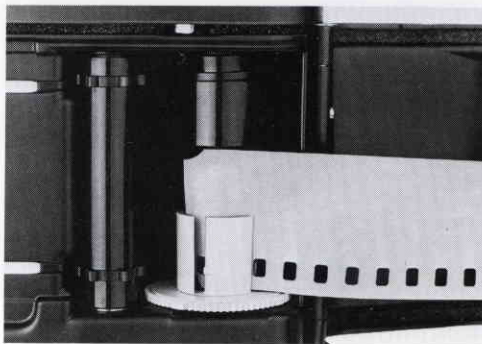

Transport the film through one frame with the rapid transport lever so that it will be taut in the film guide and the film cartridge mouth is not proud.

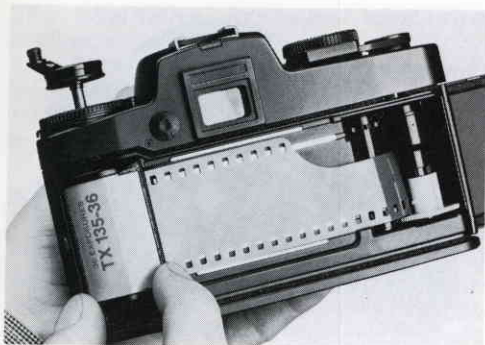

Close the camera by snapping the camera back shut. Release the shutter. Transport the film through one frame and again release the shutter. Transport the film once again. The camera is now ready for operation. The film counter (1) points at 1. It counts forward to "36". For the various lengths of film the numbers "20", "24", and "36" are marked in red.

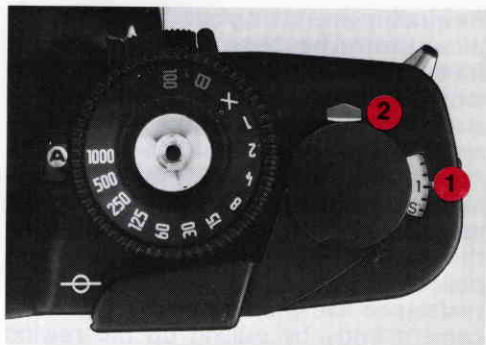

Ret.-Nr. 24 558-111

The film has been correctly inserted and is transported when a bright field becomes visible in the control window (2) in front of the rapid transport lever; it advances towards the front edge of the window with each exposure.

Rewinding and taking out the film

When the film has been exposed to the last frame the rapid transport lever can no longer be operated. Before the film is removed from the camera it must be rewound into its cartridge. Press the rewind release button (31) on the underside of the camera body, turn out the rewind crank and rotate it clockwise (in the direction of the arrow) until the film is pulled out of the take-up spool after slight resistance has been overcome. Open the camera body by pulling up the rewind crank and take out the film cartridge.

Change films in the shadow of your body.



Switching on the exposure system

The exposure system of the LEICA R 4 is switched on with slight pressure of the release button (4) or pressure of the locking button on the program selector (6). The LED displays in the viewfinder lights up.

The alternative exposure measuring methods

The LEICA R 4 has an exposure measuring system with alternative measuring methods:

- LEITZ largefield integrating measurement
- LEITZ selective measurement

These exposure measurement methods are combined with the operating modes of automatic shutter speed control, automatic aperture control and manual setting of shutter speed and aperture, i.e. they are combined into programs.

The exposure is measured through the lens. With the LEICA R lenses with fully automatic preset diaphragm measurement is carried out at full aperture. The symbol of the measuring method employed is displayed in the viewing window (7) next to the program selector and in the bottom left-hand corner of the viewfinder as a program. The exposure is measured by a silicon photo diode housed in the bottom part of the camera where it is protected against stray light.

Sensitivity of the exposure meter

The measuring range with integrating measurement is 0.25 cd/m^2 to 63000 cd/m^2 at $f/1.4$. In exposure values (EF): at ISO 100/21° from +1 to +19, or $f/1.4/1 \text{ sec}$ to $f/22/1000 \text{ sec}$. The measuring range with selective measurement is 1 cd/m^2 to 6300 cd/m^2 at $f/1.4$. In exposure values (EF): at ISO 100/21° from +3 to +19, or $f/1.4/1/4 \text{ sec}$ to $f/22/1/1000 \text{ sec}$.

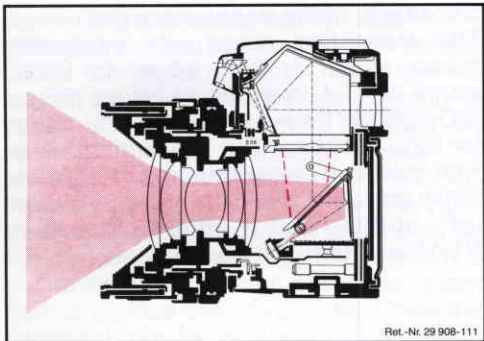

LEITZ largefield integrating measurement

Most photographic subjects are composed of details of varied brightness. The reflection of such ordinary subjects corresponds to that of a mean grey value of 18%, for which every exposure meter is calibrated.

As a rule the details of varied brightness are equally distributed throughout the entire field. Here the programs with large-field integrating measurement **A**, **T** or **P** (see pp. 24 to 33) should be chosen.

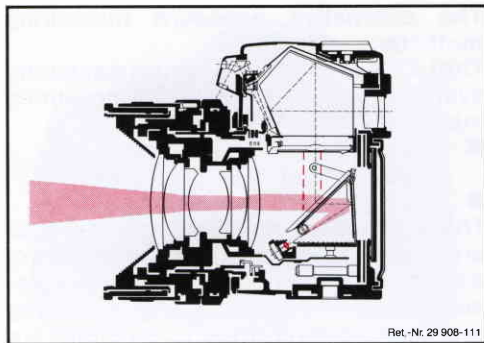

LEITZ selective measurement

This method is used whenever great brightness differences occur in the entire subject and a certain detail is to be exposed accurately.

The measuring field is exactly outlined in the viewfinder by the large central circle. It is indicated at the same size and clarity for all focal lengths and all focusing screens. The programs with selective measurement are called **A** and **m** (see pp. 24 to 33).

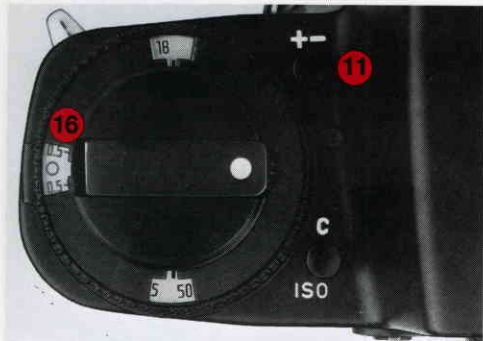

Ref.-Nr. 24 564-111

Exposure correction (override)

Exposure meters are calibrated for a mean grey value corresponding to the brightness of an ordinary photographic subject. If the subject of which a reading is taken does not meet these requirements, a suitable exposure correction must be applied.

Exposure corrections are used particularly with largefield integrating measurements. With selective measurement, as a rule, a representative detail of average grey value can be selected from the entire subject for a reading through the smaller

and precisely defined measuring field. Here a correction is not required.

Example for a "+" correction

With very bright subjects, such as snowscapes, or the beach, the exposure meter, owing to the greater reflection of the light, will indicate a shutter speed which is too high and therefore produces underexposure. Consequently the shutter speed must be reduced, for instance from 1/125 to 1/60 sec.

This is done with the "+1" correction.

Example of a "-" correction

With very dark subjects which reflect little light the exposure meter will indicate a shutter speed which is too slow and therefore produces overexposure. Consequently the shutter speed must therefore be increased, for instance from 1/15 to 1/30 sec. through the "-1" correction.

To set the correction a locking button (11) is pressed and the scale (16) set to the desired value with the lever next to it. Half exposure values up to +/-2 can be set and clamped. At the end values of the ISO (ASA/DIN) scale, exposure corrections can be set only within limitations.

When the camera is switched on, the override symbol  will blink in the bottom left-hand corner of the viewfinder when a correction has been set.



Ret.-Nr. 29 932-111

Measurement with working aperture

Some accessories such as extreme telephoto lenses, the 3-part ring combination, and the Universal Focusing Bellows R do not incorporate an automatic diaphragm. The exposure must be measured with the working aperture. Here the photo diode will receive more or less light as the lens aperture is adjusted. The rest of the operation is identical with that with lenses with automatic diaphragm.

Values below the measuring range

The measuring range of the camera used for correct exposures is linear. When in very poor light this range is not reached, these conditions no longer apply and an accurate exposure can no longer be determined. The measuring values indicated in the viewfinder will lead to wrong results. A warning signal is therefore given by a constant lighting up of the override symbol . In the transitional range the symbol will blink.

Long-time range

The working range of the exposure meter of the LEICA R 4 depends on the measuring sensitivity of the photo diode, the film speed setting, and the speed of the lens. The highest shutter speed measured or determined is 1/1000sec., the slowest about 8 sec. Minor deviations in the automatic long-time range from about 2sec and longer (dotted in the diagram) can be ignored in practice. In the viewfinder the shutter speeds from 1/1000sec to "1sec or longer" are displayed. In addition an indication is given by the override symbol when the measuring range is not being reached, i.e. if a correct exposure is impossible. The diagram (see next page) indicates the working range of the exposure meter.

When the f/1.4 lens is used the slowest shutter speed to be measured or determined is:

ISO 800/30° = 1/8sec

ISO 400/27° = 1/4sec

ISO 200/24° = 1/2sec

ISO 100/21° = 1sec

Because as a rule high-speed films and high-speed lenses are used in poor lighting conditions this will hardly impose limitations. Even when the lens is stopped down 3 stops (with ISO 100/21°) the shutter speed will still be determined automatically (although it will not be indicated).

Needless to say measurements can also be carried out at full aperture, the shutter speed measured converted for a different aperture value, and the exposure made at the "B" setting.

For slow films the following values are produced in the same conditions:

ISO 50/18° = 2sec

ISO 25/15° = 4sec

ISO 12/12° = 8sec

Here the indication is "1sec and longer". In practice this is of hardly any significance, because as a rule long time exposures are made from a tripod. Whether the film is exposed for 2, 3, 4, or 8 seconds is practically immaterial.

The exposure is correct as long as the override symbol in the viewfinder of the LEICA R 4 does not light up.

Working diagram of the exposure meter

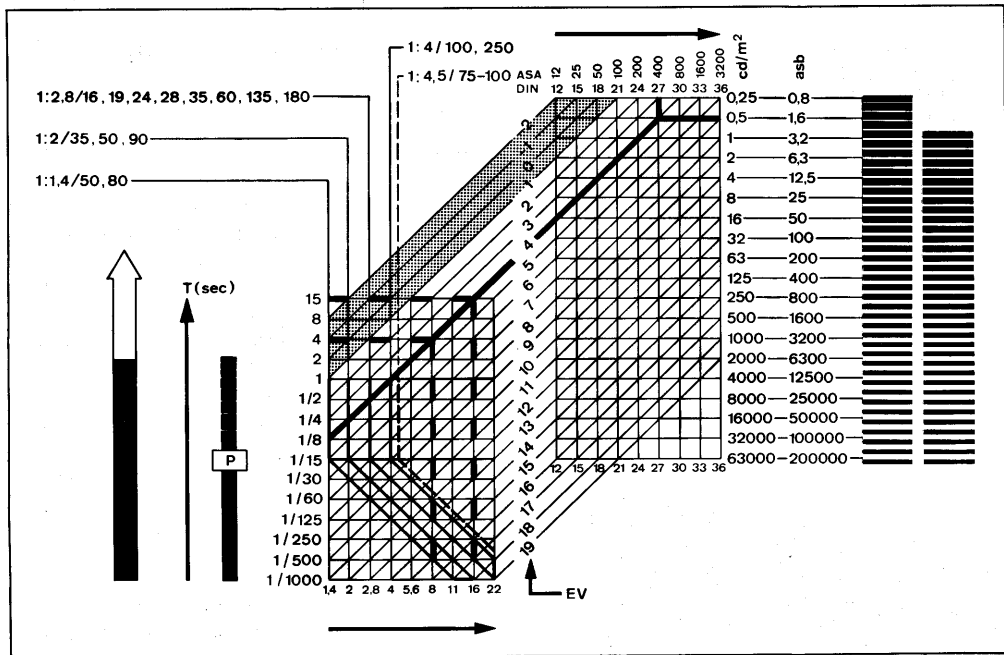

All the important data of the exposure measuring system of the LEICA R 4, such as the measuring sensitivity and measuring range, are displayed in the working diagram.

Example of long-time exposure:

Lens: 50mm SUMMILUX®-R f/1.4

Aperture setting: f/1.4

Film speed: ISO 400/27°

The lowest luminous density (for instance in candle light) measured is 0.5cd/sq.m. This corresponds to the exposure value 4 and produces a shutter speed (T) of 1/8sec at f/8 of 4sec, and at f/16 of 15sec.

Example of automatic program

In the bottom left-hand corner of the diagram the combinations of shutter speed and aperture can be read which are determined by automatic program **P** as a function of the lens speed, the available light and the film speed.

Lens: 50m SUMMICRON®-R f/2

Luminous density: 2000cd/sq.m.

(bright sunlight)

Film speed: ISO 25/15°

Corresponding to the exposure value 12 a combination of f/5.6 and 1/125sec shutter speed is produced.

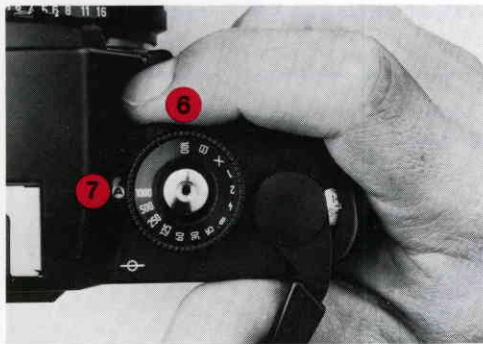

Choice of programs

The programs are set by pressure of the locking button and simultaneous sliding of the program selector (6). As the locking button is being pressed the camera is switched on. The chosen program is displayed in the bottom left-hand corner of the viewfinder window. In addition, the program setting can be read at any time in the viewing window (7) next to the shutter speed ring.

The program selector must engage in the chosen position. It can be reset only after the locking button has been pressed.

The following programs can be chosen:

- A** **automatic shutter speed control** with LEITZ largefield integrating measurement
- A** **automatic shutter speed control** with LEITZ selective measurement
- T** **automatic aperture control** with LEITZ largefield integrating measurement
- P** **automatic program** with LEITZ largefield integrating measurement
- M** **manual setting** of shutter speed and lens aperture with LEITZ selective measurement

Shutter speed ring

With the **T** and **m** programs the shutter speeds are set with the shutter speed ring. It engages at all the indicated values. The shutter speeds from 1/1000 to 1sec are determined electronically. Intermediate values cannot be set.

In the **A**, **A**, and **P** programs the shutter speed ring may be set for any desired value except "X", "100", and "B". All shutter speeds between 1/1000 and 1sec are determined continuously and displayed on the right in the viewfinder window by LEDs. If 2 diodes light up simultaneously, the values produced are intermediate.

Longer exposure times of up to about 8sec are also produced automatically, but not displayed in the viewfinder, see diagram page 20.

The use of electronic flash units requires the "X" setting. At "B" the shutter remains open as long as the release button is being pressed.

"B" and "100" (=1/100sec) can be used without batteries.



Ref.-Nr 24 640-111

At "X", "B" and "100" the exposure is not measured even when the button cells are inserted. This is indicated in the viewfinder by the lighting up of the upper triangular LED.



Ret.-Nr 24 634-111

A automatic shutter-speed control with LEITZ largefield integrating measurement.

Preselected the desired lens aperture

This program is particularly suitable when the main element of composition is the depth of field and normal lighting conditions prevail.

This program is used, for instance, for landscape and architectural photography. The range of the depth of field is determined with the aperture preselection ring (21). The shutter speed is automatically

determined according to the existing brightness. The shutter speed ring may be set at any value between 1/1000 and 1 sec, but not at "X", "100" or "B".

The **A** program functions with all LEICA R lenses and accessories such as adapters, Universal Focusing Bellows-R, etc., see page 50).

Viewfinder displays:

The program setting is displayed in the bottom left-hand corner of the viewfinder window, the preset aperture to the right of it.

The time scale is visible on the right in the viewfinder frame. The automatically produced shutter speed is indicated by an LED next to the figures. The shutter speeds are produced continuously, two LEDs light up with intermediate values.

Speeds of 1/60sec and higher are indicated by circular, of 1/30sec and slower

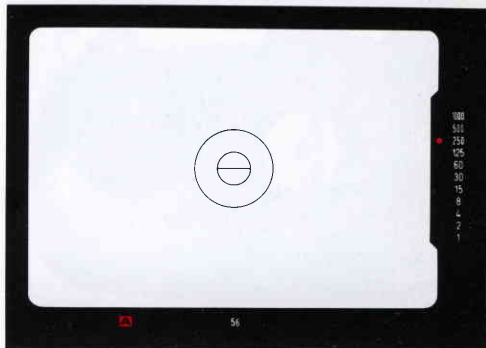

Ret.-Nr. 29 928-111

by square LEDs. The LEDs indicate the danger of camera shake.

With extreme brightness the shutter speed range may no longer be adequate for the preselected aperture. This is indicated by a red triangular LED at the **top** end of the scale. When the **bottom** triangular LED lights up the shutter speed is 1 sec or longer. As long as the symbol ▼ in the viewfinder of the LEICA R 4 does not light up, the exposure is correct.



Ref.-Nr 24 640-111

A automatic shutter-speed control
with LEITZ selective measurement
Preselected the desired lens
aperture

This is the right program when you have to work with depth of field and to take spot readings, for instance portrait in contre jour light, or spot-lit stage scenery.

The limits of the depth of field are determined with the aperture preselection ring (21). The shutter speed is automatically determined as a function of the existing brightness.

The shutter-speed ring be set at any value between 1/1000 and 1sec, but not at "X", "100" and "B".

The program **A** functions with all LEICA R lenses and accessories, such as adapters, Universal Focusing Bellows-R etc. (see page 50).

Measured-value storage

The exposure meter covers only the field in the central large circle of the viewfinder. If the part of the subject representative of the exposure measurement is not be in the centre of the desired picture, the measured value can be stored when the slack is taken off the release button (4). The program LED is extinguished. If the release button is maintained in this position the camera can be panned until the desired picture area has been determined. The release button is now pressed. The shutter speed can be stored for about 30sec. The LED display of the shutter speed remains functional and indicates any changes in the lighting conditions. The measured value is extinguished as soon as the finger is removed from the release button.

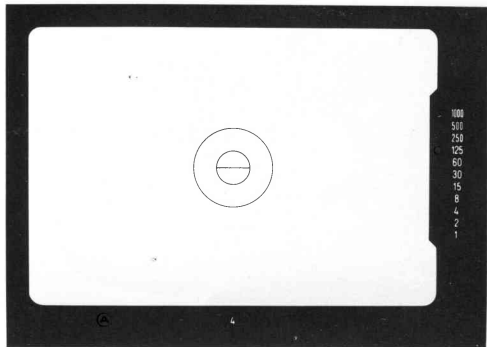

Ref.-Nr. 29 929-111

Viewfinder displays:

The program setting is displayed in the bottom left-hand corner of the viewfinder window, the preset aperture to the right of it.

The time scale is visible on the right in the viewfinder frame. The automatically produced shutter speed is indicated by an LED next to the figures. The shutter speeds are produced continuously, two LEDs light up with intermediate values.

Speeds of 1/60sec and higher are indicated by circular, of 1/30sec and slower by square LEDs. The LEDs indicate the danger of camera shake.

With extreme brightness the shutter speed range may no longer be adequate for the preselected aperture. This is indicated by a red triangular LED at the **top** end of the scale. When the **bottom** triangular LED lights up the shutter speed is 1sec or longer. As long as the symbol ∇ in the viewfinder of the LEICA R 4 does not light up, the exposure is correct.



Ret.-Nr. 24 639-111

T **automatic aperture control** with LEITZ largefield integrating measurement.

Preselect the desired shutter Speed, set the minimum lens aperture.

This program is used above all for quickly moving subjects, where the shutter speed is the element of composition. This applies particularly to movement sequences, such as sports subjects, exposures from an unsteady support, or with long-focal-length lenses.

With a high shutter speed rapid movements can be photographed at perfect contour sharpness. A slower shutter speed produces deliberate movement blur, which may enhance the pictorial dynamism.

The desired shutter speed is preselected on the shutter speed ring, which engages at the engraved values. Intermediate settings are not effective. The lens aperture is automatically determined as a function of the existing brightness.

Important

The lens must be stopped down to its minimum aperture (f/16 or f/22 respectively) so that the entire aperture range is available for the automatic control.

The **T** program functions with all LEICA R lenses with fully automatic diaphragm (see pp. 46 and 50).

Viewfinder displays:

The program setting is displayed in the bottom left-hand corner of the viewfinder, the preselected shutter speed in the bottom right. The aperture settings is faded in at bottom centre. If the lens has not been fully stopped down, the program display bottom left blinks and the aperture values on the right in the viewfinder frame are, if at all, incorrectly displayed. If the lens is still not stopped down to its minimum aperture, the shutter speed will be automatically adjusted independently of the preselected and displayed speed (up to 1/1000sec).

The aperture scale is visible on the right in the viewfinder frame. The automatically determined lens aperture is indicated by an LED next to the figures. The apertures are produced continuously, two LEDs will light up with intermediate values. f/8 and smaller is indicated by circular, f/5.6 and larger by square LEDs. The square LEDs indicate shallow depth of field.

At extreme brightness or with very little light the aperture range may no longer be adequate for the preselected shutter speed. This is indicated by a red triangular LED: with overexposure at the **top** end of

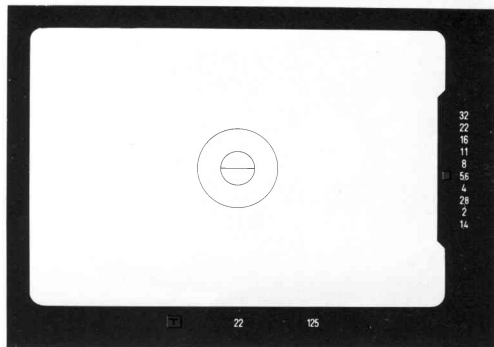

Ret.-Nr. 29 931-111

the aperture scale, with underexposure at the **bottom** end, and through constant lighting of the  symbol.

If it is possible within the shutter speed range (1/1000 to about 8sec), however, correction is introduced through automatic change of the preselected shutter speed.

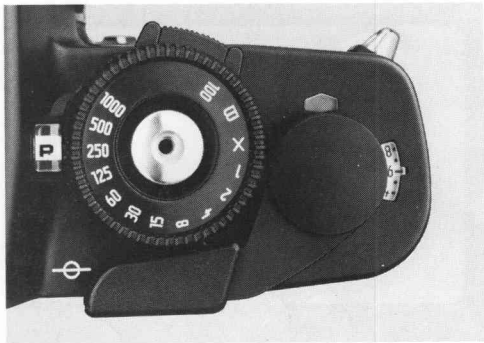

Ref.-Nr 24 642-111

P **automatic program with LEITZ**
largefield integrating measurement.
Set the minimum aperture of the
lens.

This is the best program for constant action readiness. It is also eminently suitable for relaxed photography without any technical knowledge.

The camera automatically and continuously sets the shutter speed and lens aperture. The shutter-speed ring may be set between any value between 1/1000 and 1sec, but not at "X", "100" and "B".

Important

The lens must be stopped down to its minimum aperture (f/16 or f/22 respectively) so that the entire aperture range is available for the automatic control.

The **P** program functions with all LEICA R lenses with fully automatic diaphragm (see pp. 46 and 50).

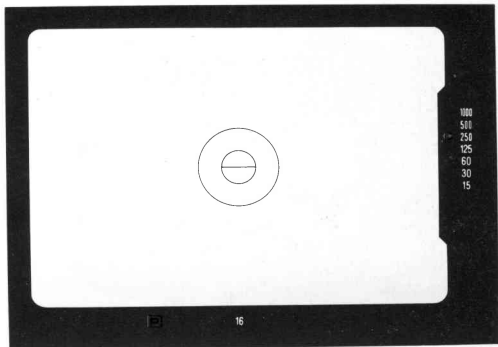

Ref.-Nr. 29 930-111

Viewfinder display

The program setting is visible in the bottom left-hand corner in the viewfinder. The aperture setting is faded into the bottom centre. If the lens has not been completely stopped down, the program display in the bottom left-hand corner blinks. If the lens is still not stopped down to its minimum aperture, the shutter speed is automatically adjusted (up to 1/1000sec). The shutter-speed scale is visible on the right in the viewfinder frame. The automatically determined shutter speed is indicated by an LED next to the figures.

The display of the slow speeds from 1/8 to 1 sec is blanked; but these speeds are also automatically produced. The blanking indicates the danger of camera shake. In extreme brightness or with very little light the automatically controlled shutter speed/aperture range is no longer adequate. This is indicated by a red triangular LED: with overexposure at the **top** end of the shutter speed scale, with underexposure at the **bottom** end, and through a constant lighting up of the **▽** symbol.

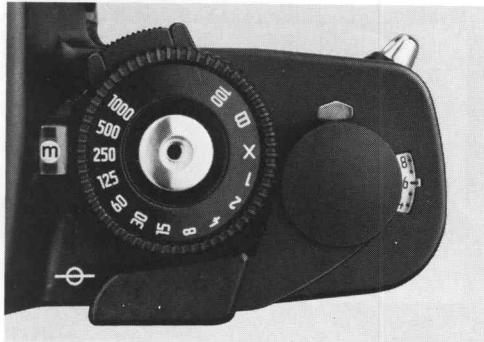

Ret.-Nr. 24 641-111

m manual setting with LEITZ selective measurement.
Set shutter speed and lens aperture manually.

In certain exposure situations the switching-off of the automatic exposure control is desirable. Shutter speed and aperture are set manually in steps. The exposure value, i.e. the shutter speed/aperture combination must be determined before the exposure. There is a choice of 2 possibilities:

- 1) Preselect aperture, switch on the camera by pressing the locking button on the program selector or touching the release button and line up the subject. Set the shutter speed indicated by the red LED on the shutter-speed ring. Intermediate values cannot be set. If two LEDs light up during the determination of the shutter speed, the aperture should be opened or closed by half a value.

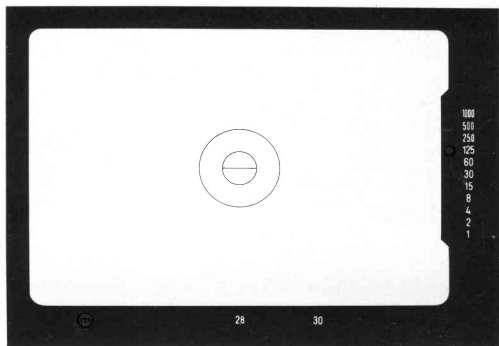

Ref.-Nr. 29 932-111

- 2) Preselect the shutter speed by rotating the shutter-speed ring engaging it at full values. Line up the subject and adjust the lens aperture with the camera switched on until the shutter speed indicated by red LEDs on the right in the viewfinder frame agrees with the preselected shutter speed.

The **m** program functions with all LEICA R lenses and accessories, such as adapters, Universal Focusing Bellows-R, etc. (see page 50).

Viewfinder displays:

The program setting is visible in the bottom left-hand corner in the viewfinder with preselected shutter speed bottom right, the preselected aperture bottom centre. The shutter-speed scale is visible on the right in the viewfinder frame. The LEDs indicate the measured shutter speed. When the triangular LED at the top or bottom on the shutter-speed scale lights up (too bright, or too dark), choose a different shutter/aperture combination. If necessary use faster lenses or lower or faster films.

The viewfinder as a composition and control centre

The viewfinder of the LEICA R 4 is the centre for the composition and control of all important items of information:

Sharpness, picture area and perspective can be easily assessed, the field for the selective exposure measurement can be clearly distinguished. The viewfinder covers 92% of the film format, the viewfinder magnification is 0.85 with the 50mm lens in the camera at the infinity position. All the necessary values are displayed in the viewfinder corresponding to the program setting. The LED displays light up when the locking button on the program selector or the release button is being pressed. To prevent confusion in the viewfinder, only those items of information are indicated with the various programs that are necessary (see pp. 22 to 35).

The illustration opposite shows all the displays simultaneously.

The display in the bottom left-hand corner in the viewfinder frame indicates override and the limit of the measuring range, to the right of it is the display of the program setting. In the bottom centre the preselected lens aperture is faded in, and on the bottom right the preselected shutter speed.

On the right of the viewfinder frame the aperture scale or the shutter speed scale is visible; to the left of it the line of LEDs with warning display for overexposure at the top and underexposure at the bottom. The square LEDs indicate the danger of camera shake or a shallow depth of field. A circle in the centre of the viewfinder indicates the field for the LEITZ selective measurement. The illustration shows the universal focusing screen.



Ret.-Nr 29 933-111

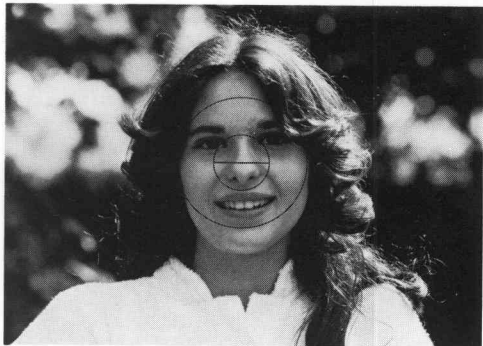

Ret.-Nr. 29 971-111

Focusing with the universal focusing screen

Normally the LEICAR 4 is supplied with the universal focusing screen, which is bright, contrasty, and can be used universally for the most frequent photographic situations.

The image is focused by rotation of the distance setting ring (23) on the lens.

When the image is out of focus, the edges and lines of the object are mutually displaced in the horizontal split wedge of the viewfinder.

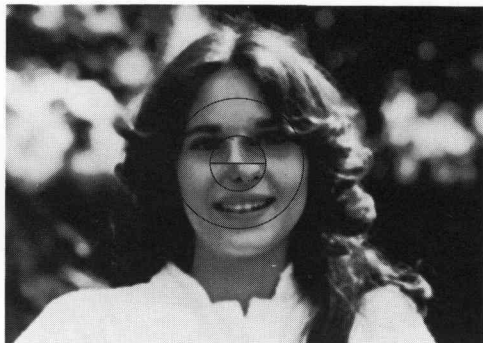

Ret.-Nr. 29 970-111

A ring with a rectangular-prism screen surrounds the central split wedge. It serves for the focusing of objects with weak contours. The out-of-focus position is clearly indicated by flickering. The outer boundary of this ring indicates the outline of the field for LEITZ selective measurement.

The surrounding field consists of matt triangular prisms, which produce a groundglass screen effect. Here the image is focused above all with long-focal-length lenses and in the near-focusing range.

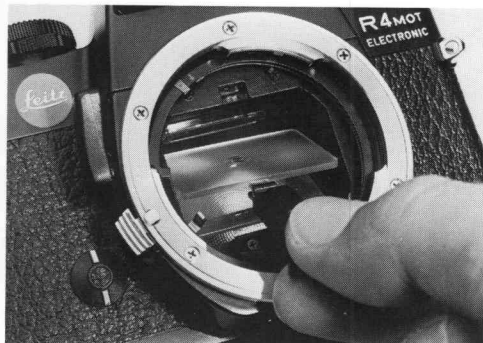

Ref.-Nr. L 24 728-111

Interchangeable focusing screens

In addition to the universal screen four other focusing screens are available for the LEICA R 4. They are supplied singly in a container with tweezers for interchange and a dust brush.

Important

Exchange all focusing screens only with their appropriate tweezers (see instructions "Interchangeable focusing screens"). Do not touch them with your fingers.

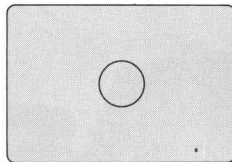

2

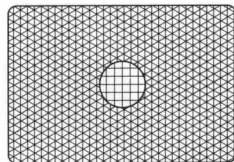

3

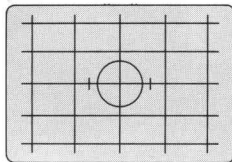

4

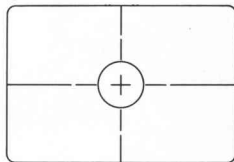

5

Special tasks call for tailor-made systems for rapid and accurate work. This is why four additional focusing screens are available for the LEICA R 4: the uniform groundglass screen (No. 2) for the extreme close-up range and very long-focal-length lenses. The microprism screen (No. 3) for undisturbed assessment of the pictorial composition. The uniform groundglass screen with grid division (No. 4) for architectural photography and reproductions. The clear glass plate (No. 5) for scientific photography such as photomicrography and astronomical photography.

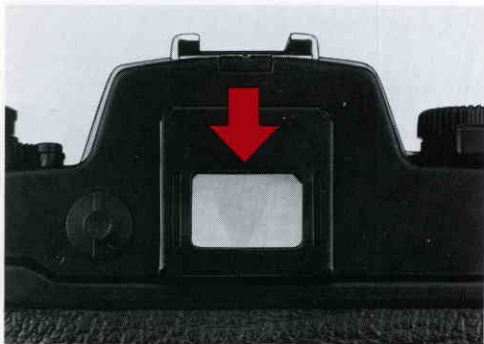

Correction lenses

For the full utilization of the potentialities and of the outstanding performance of the LEICA R lenses the viewfinder image must be seen at optimum sharpness.

Whether the camera is used with or without spectacles, it must be possible to see objects at 1m distance in sharp focus. Failing this the measuring edge of the split image rangefinder cannot appear in sharp focus and good contrast in the viewfinder. This precludes precision focusing.

Here we recommend the use of a correc-

tion lens. The LEITZ correction lenses are available in the following + and - dioptre values (spherical):

0.5 - 1.0 - 1.5 - 2.0 - 3.0



Eyepiece blanking

The silicon photo diode of the exposure meter of the LEICA R 4 is in the bottom space of the camera where it is protected against light. This is why light entering through the viewfinder eyepiece can affect the measuring result only in extreme cases, for instance when the user does not look through the viewfinder when taking photographs from a tripod and direct sunlight or powerful spotlights enter the eyepiece from the rear.

A switch (27) is arranged on the left of the eyepiece window; turning it anticlockwise closes the eyepiece. When the stop is swung in, a white dot will appear in the eyepiece.



Multiple exposures

Make the first exposure. Press the rewind button (31). Operate the rapid transport lever. The already exposed film can now be exposed once again.

At the end of its travel the rapid transport lever automatically switches off the rewind button. If further exposures on the same frame are desired, the rewind button must be pressed again before each operation of the transport lever.

For multiple exposures with the MOTOR-WINDER or MOTOR-DRIVE see instructions for these accessories.



Self-timer

Set the delay time of about 8sec by turning the knob (17) clockwise (direction of the arrow) through 30°. The self-timer starts when the camera is switched on by a slight touch of the release button or by pressure of the locking button of the program selector. The blinking LED (10) visually indicates the function. About 2 seconds before the camera is released blinking gives way to constant light. To disengage the self-timer, simply turn the knob (17) back.

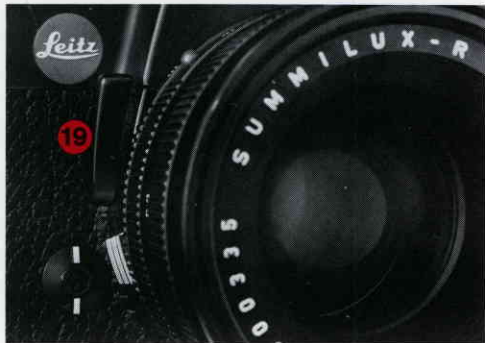

Depth-of-field lever

The LEICA R 4 measures the exposure at full lens aperture. When the depth-of-field lever (19) is operated the lens aperture closes to the preselected value and permits assessment of the sharpness/unsharpness range. This is particularly useful with close-up subjects.

Important

During exposure measurement the lever must not be pressed; this would produce wrong exposure values.



Depth-of-field scale of the lenses

The depth-of-field scale indicates the range of the depth of field for the object distance set on the camera.

If, for instance, the 50mm SUMMICRON-R f/2 lens has been focused on 5m, the depth of field will extend from 3 to about 20m when the lens has been stopped down to f/11. If it has been stopped down only to f/4, sharpness will extend from 4 to about 8m.

Our depth-of-field table (No. 110-57) contains detailed information about the depth of field at all focal lengths.

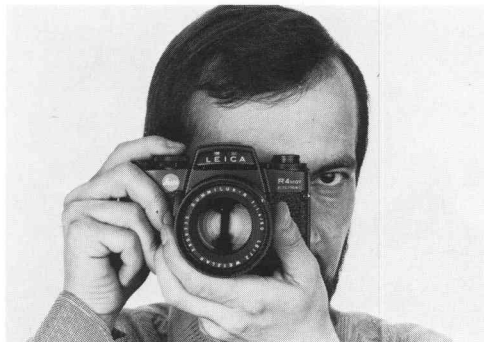

Ref.-Nr. L 24 663-111

Holding the camera correctly

To ensure steady 3-point support the right hand grips the camera. The index finger rests on the release button (4), the thumb on the rapid transport lever (3). The left hand supports the lens from below.



Ref.-Nr. 24 664-111

Simply turn the camera for upright pictures. The hands remain in the same position as for horizontal pictures, ready to transport the film and for focusing.

Flash synchronisation

The LEICA R 4 accepts all commercially available electronic flash units with standardized flash contacts (coaxial plugs) or with centre contact.

The contact (24) for cable connection (X contact) is found on the left-hand front of the camera.

Flash units with centre contact are connected to the "X" flash contact in the accessory shoe. For work with electronic flash units the shutter ring is as a rule set at "X" (1/100sec). With manual setting flash synchronisation is ensured also with slower shutter speeds and at "B".

This applies to automatic mode only when modern thyristor-fired flash units are used.

When the camera batteries are exhausted, exposures with flash units can still be made if the shutter speed ring is set at "100".

Bulb flashes are also connected through the contact bush (24) for centre contact in the accessory shoe. The table on the following page provides information about the shutter speeds for synchronisation.



Electronic flash		X, 100 (1/100) 1 → 1/60, B*
Flash bulbs	AG 1 AG 3 Flash cube PF 1 XM 1	1 → 1/30, B
	M2	1 → 1/60, B
	PF 5 XM 5 M 3 25 GE 5	1 → 1/30, B
	FP 26 PF 6 XM 6	1 → 1/15, B
	PF 45	1 → 1/15, B
	PF 60	1 → 1/30, B
	PF 100	1 → 1/15, B

* See page 43

Trough system-compatible electronic flash units automatic switchover of the camera electronics to "X" (1/100sec) when the flash unit has been fully charged, effective with all programs. **With automatic aperture control and automatic program the aperture is no longer produced automatically. It closes to the set value.**

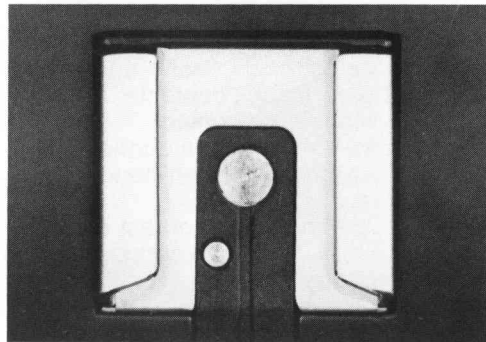

Automatic switch-over to "X"

The accessory shoe of the LEICA R 4 has an additional control contact for system-compatible flash units. These are offered by various manufacturers and automatically control the switch-over to "X" as soon as the unit has been recycled. Flash readiness is indicated by the blinking triangular LED in the top right-hand corner of the viewfinder of the LEICA R 4. In the absence of flash readiness or when the unit has been switched off, the camera automatically returns to the selected program.



Ref.-Nr. 24 617-111

Interchangeable lenses

The LEICA R system offers the basis for optimum adaptation to any photographic task or situation. The comprehensive

range of lenses extends from the fisheye to the zoom lens, from the distortion-free 15mm ultra-wide angle to the 800mm telephoto lens.



Design of the LEICA R lenses

All LEICA R lenses share the external design, i.e. the arrangement of the rotatable aperture preselection ring (21), the fixed ring with depth-of-field indication (22), and the distance setting ring (23) is the same. The left hand therefore soon becomes accustomed to quick and reliable operation with all focal length.

Automatic spring-back diaphragm

LEICA R lenses have spring-back diaphragms. This means that the viewfinder image is always – i.e. before and after the exposure – seen at full aperture and therefore at maximum viewfinder brightness. Shortly before the exposure or when the depth of field lever is depressed the lens diaphragm closes to the pre-selected value.

See "Measurement with working aperture, page 18 for the following lenses: 35mm PA-CURTAGON® -R f/4, 400mm TELYT® -R f/6.8, 500mm MR-TELYT-R f/8, 560mm TELYT-R f/6.8, and 800mm TELYT-S f/6.3.

Lens hoods

A functionally-designed lens hood is part of all LEICA R lenses. It should always be used, because it offers effective protection against stray light and glare as well as against raindrops and finger marks. Most LEICA R lenses have a built-on extensible lens hood.

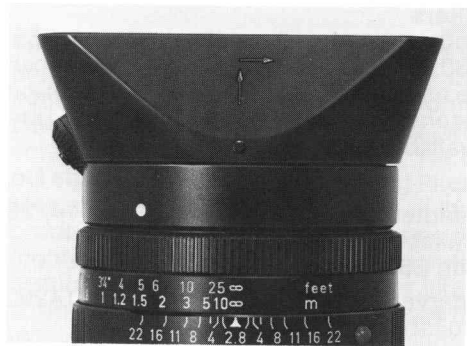

From some lenses the lens hood can be detached. It is attached – white dot facing white dot – and locked by a clockwise turn. To unlock it, slightly raise the lens hood and release it by an anticlockwise turn. This lens hood also serves as an adapter for series filters.

Filters

Both screw-in filters (for instance E55, E60, E67) and series 7, 7.5 or 8 filters can be used with LEICA R lenses with built-on extensible lens hood. Adapters are available for series filters:

Code No.

Adapter for Series 7 filters . . . 14225
(suitable for lenses
with E55 thread)

Adapter for Series 7.5 filters . . . 14263
(suitable for lenses
with E60 thread)

Adapter for Series 8 filters . . . 14264
(suitable for lenses
with E67 thread)

The adapter ring can be easily released when, to avoid distortion, it is gripped only on one side.

Screw-in filters are preferable. This applies particularly to circularly polarising filters because of simple handling. With lenses with detachable lens hood the use of series filters is recommended. Here the lens hood also functions as a filter adapter: the filters are first inserted in the lens hood and in this combination attached to the



lens (does not apply to the 19mm ELMARIT®-R f/2.8). Rotating devices are fitted to the 24mm and the 28mm ELMARIT-R f/2.8 and the 35mm PA-CURTAGON-R f/4 lenses.

The use of filters

When the exposure is measured through the lens, the reduction of the light intensity is generally automatically allowed for. But the various films have different sensitivities in the various regions of the spectrum. Deviations from the measured value can therefore occur with dense and extreme filters.

Thus, orange filters for instance as a rule call for an extension by one aperture value, red filters on average by about 2 values. A generally valid figure cannot be quoted, because the red sensitivity of black-and-white films varies widely.

Through the circularly polarizing filters we supply for our lenses measurement and setting can be carried out as for normal filters both with integrating and with selective exposure measurement. We do not recommend linearly polarizing filters. Measurement through such filters produces strong deviations, because the highly effective multiple coating of the semitransparent main mirror acts like a strong polarizer. This applies to both the extinction and the transmission position of the polarizing filter.

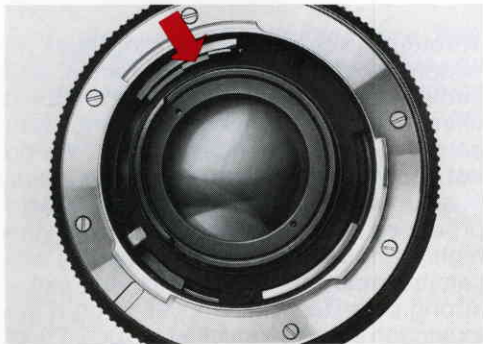

Ref.-Nr. 22 968-111

Hints for the use of existing LEICA R lenses and LEICA R accessories

All lenses and the accessories of the LEICA R 3 / R 3-MOT range can be used on the LEICA R 4 without modification.

The 180mm ELMARIT-R f/2.8 lens up to Serial No. 2939700 and the 250mm TELYT-R f/4 lens up to Serial No. 3050600 and the accessories can, however, be used only with automatic shutter-speed control with LEITZ largefield integrating measurement, automatic shutter-speed control with LEITZ selective measurement, and manual setting.

Lenses and accessories of the LEICA-FLEX[®] models (without control cam) can be fitted with such a cam (see illustration) at any time for use of the LEICA R exposure measuring methods. The functions of modified lenses and accessories on all LEICAFLEX models remain unrestricted.



Ret.-Nr. 24 625-111

LEICA M lenses on the LEICA R 4

All the lenses of the LEICA M range suitable for use on the VISOFLEX® attachment can also be used on the LEICA R 4. The operating conditions, for instance camera distance and achievable object area sizes, will then be the same as when these M lenses are used on the VISOFLEX. A special adapter (Code No. 14167) forms the bridge between the two LEITZ systems of 35mm photography. These lenses have no auto-diaphragm. The exposure is measured at the working aperture (see page 18).

Hints for the care of the LEICA R 4 and its lenses

It is best to remove dust and fluff on the mirror carefully with a soft, dry sable brush, from which grease is repeatedly removed with ether before and during cleaning. For the cleaning operation itself, the brush must be absolutely dry.

Take care not to damage the focusing screen mechanically, for instance with the mount of the brush.

Do not blow into the mirror chamber, because this may introduce dust into the interior of the camera.

A camera lens acts as a burning glass when it is pointed into direct sunlight. The camera should therefore be protected by means of the lens cap, or should be kept in the everready case and placed in the shade. In addition to its type designation each lens has its individual Serial No. Please make a note of this as well as that of your camera, which you find on the base-plate of your LEICA R 4. This may be very important in case of loss.

Dust on the external surfaces of the lenses is removed with a soft sable brush, or a clean, dry, soft piece of lint used carefully. Special spectacle cleaning tissue is not recommended. This is impregnated with chemicals which may attack the glasses of the camera lens. (The glass used for spectacles is of a composition different to that optical glasses for high-quality camera lenses).

In unfavourable conditions, for instance by the seaside, in subtropical regions, etc., a colourless UV filter protects the front lens against external influences such as seawater spray and sand. An additional colourless and optically flat glass plate, i.e. a filter, can, however, cause undesirable reflections at certain angles of incidence of the light, especially in contre jour light and high contrast. The lens hood protects the lens also against accidental finger-marks and raindrops.



Ref.-Nr. 24 600-111

MOTOR-WINDER R 4, MOTOR-DRIVE R 4

The MOTOR-WINDER R 4 and MOTOR-DRIVE R 4 on the LEICA R 4 make motorized film transport and shutter wind possible. With the winder frame frequencies of up to 2fps and with the drive of up to 4fps are possible. The drive can be switched to 2fps and to single-frame exposures. All shutter speeds from 1 to 1/1000sec can be used. The WINDER is powered by 6, the DRIVE by 10 commercially available alkali manganese batteries or NiCd rechargeable batteries.



Ref.-Nr. 24 659-111

MOTOR-WINDER R 4, Code No. 14282



Ref.-Nr. 24 620-111

MOTOR-DRIVE R 4, Code No. 14292

The LEICA R 4 with WINDER or DRIVE can be held more securely and comfortable with the handgrip with adjustable leather loop.

Handgrip, Code No. 14283

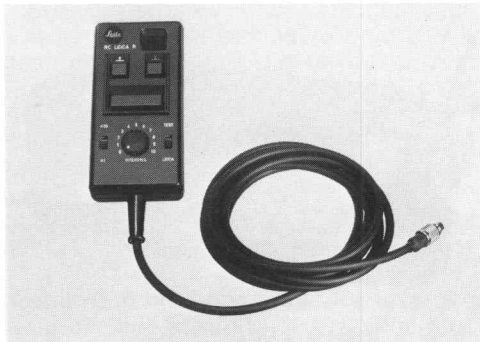

Ret.-Nr. 23 738-111

Remote-Control LEICA R electronic control unit

This handy control unit is a remote release with illuminated digital display of the completed exposure through feedback from the camera, and at the same time a timer for automatic single-frame releases at variable time intervals of about 2 frames per second to 1 frame about every 10 minutes. The RC LEICA R can be attached to the MOTOR-WINDER R 4 and to the MOTOR-DRIVE R 4.

Remote-Control LEICA R,
Code No. 14277



Ret.-Nr. 24 607-111

DB LEICA R 4 Databack

The Databack permits the inclusion of data in the picture directly during the exposure. Negatives or slides can have the date of the exposure or a letter/number code included in the bottom right-hand corner. It is thus possible, for instance, to number a series of related exposures consecutively. The databack can be inserted in the LEICA R 4 instead of the camera back. It is connected with the flash contact of the camera by means of a cable.

DB LEICA R 4 Databack,
Code No. 14297

Camera cases

Two everready cases, one with a standard and one with a large front, are available for the LEICA R 4. The front is detachable after the press stud on the back of the case has been pushed up for unlocking. The two versions of everready case can be used with the following lenses:

	Standard everready case Code No. 14 569	Everready case with large front Code No. 14 568
16mm f/2.8	-	yes
19mm f/2.8	-	without lens hood
21mm f/4	without lens hood	without lens hood
24mm f/2.8	without lens hood	yes
28mm f/2.8	without lens hood	yes
35mm f/2	yes 1)	yes
35mm f/2.8	yes 2)	yes
35mm PA	without lens hood	yes
50mm f/1.4	yes	yes
50mm f/2	yes	yes
60mm f/2.8	-	yes
80mm f/1.4	-	yes
90mm f/2	-	yes
90mm f/2.8	-	yes

1) From No. 2791417

2) From No. 2928901

In addition, combination cases are available for extensive camera outfits which include several lenses and various accessories.



Ref.-Nr. 24 652-120

Suitability for use in the tropics

Before prolonged journeys in sub-tropical regions our Technical Service offers treatment of the camera and lenses with fungicides, which largely protect the equipment against fungal attack.

Replacement parts for the camera

Camera body covers	14103
Carrying strap	14258
Flash contact cover	14314
Universal focusing screen	14303
Baseplate cover	042-840.110

Focusing screens

Uniform groundglass screen	14304
Microprism screen	14305
Uniform groundglass screen with grid division	14306
Clear-glass plate with crosslines	14307

After-Sales service

Our After-Sales Service is at your disposal for the maintenance of your LEICA R 4 and in cases damage:

ERNST LEITZ WETZLAR GMBH,

Technical Service

P.O.B. 2027

D-6330 Wetzlar, Germany

or your National Leitz Agency, a list of which accompanies every LEICA R 4. In cases of damage the conditions of the International Leitz Warranty apply.

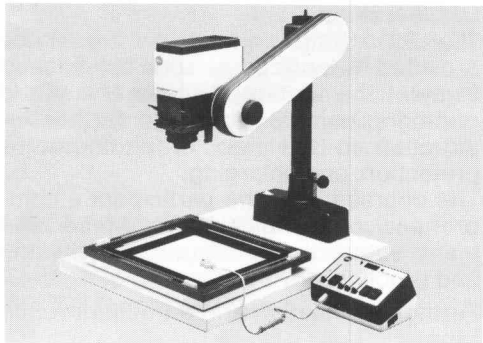

Enlargers

A top-quality camera such as the LEICA R calls for top-quality reproduction equipment.

For enlarging we supply two well-tried top quality units with automatic focusing, the FOCOMAT® V35, a pure 35mm enlarger, and the FOCOMAT IIc, a combined unit for all film formats up to 6 x 9cm.

Our prospectus No. 111.170-019 and No. 170-15 respectively provide you with detailed information.

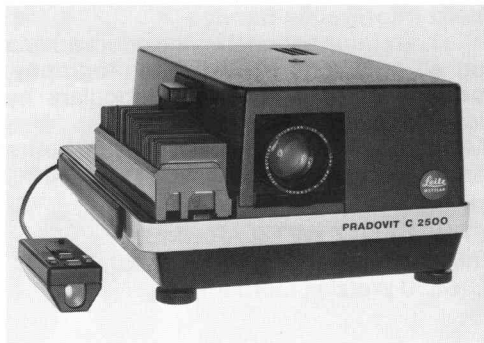

Ret.-Nr. 22 755-310

Projectors

A comprehensive range of projectors satisfies every requirement and meets every purpose of projection. They offer maximum operating convenience and versatile possibilities of extension.

The outstanding common feature of all Leitz projectors is optimum optical performance combined with traditional Leitz precision.

Please ask for descriptive literature.